

LEGEND

- | | | | |
|----------------------------|--------|--------------------------------|---------|
| PROPOSED 2' CONTOUR | —195— | PROPOSED WATER SERVICE | —WS— |
| PROPOSED 10' CONTOUR | —195x0 | EXISTING GAS MAIN | —G— |
| EXISTING 2' CONTOUR | —200 | PROPOSED GAS MAIN | —G— |
| EXISTING 10' CONTOUR | —200 | EXISTING OVERHEAD WIRES | —OH— |
| EXISTING WETLANDS | —195x0 | PROPOSED ELEC., COMMUNICATIONS | —E.COM— |
| EXISTING WETLAND BUFFER | —195x0 | EXISTING DRAIN MANHOLE | ○ DMH |
| PROPOSED SET-BACK | —195x0 | EXISTING CATCH BASIN | □ CB |
| PROPOSED EASEMENT | —195x0 | PROPOSED DRAIN MANHOLE | ○ DMH |
| EXISTING SPOT GRADE | —195x0 | PROPOSED CATCH BASIN | □ CB |
| PROPOSED SPOT GRADE | —195x0 | EXISTING FIRE HYDRANT | ○ FHY |
| EXISTING EDGE OF WOODS | —195x0 | PROPOSED FIRE HYDRANT | ○ FHY |
| PROPOSED EDGE OF WOODS | —195x0 | EXISTING WATER GATE | —WG— |
| EXISTING STONE WALL | —195x0 | EXISTING UTILITY POLE | —UP— |
| PROPOSED SILTATION BARRIER | —195x0 | EXISTING TEST PIT LOCATION | —TP— |
| PROPOSED SEWER LINE | —195x0 | EXISTING PERC TEST LOCATION | —PT— |
| EXISTING WATER MAIN | —195x0 | FENO SURVEY SPIKE & CAP | —FSC— |

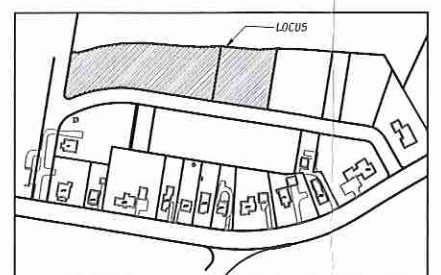

LOCUS MAP
NO SCALE

NOTES

1. NO STRUCTURES SHALL BE CONSTRUCTED WITHIN THE 50' WETLAND BUFFER.
2. AREA AT THE FACE OF THE RETAINING WALL SHALL BE RESTORED WITH A NEW ENGLAND WETLAND CONSERVATION SEED MIX.

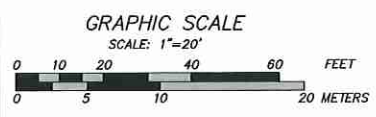

	DATE	REVISION	COMMENT
	#		
SITE PLAN KEUKA ROAD CONCORD, MASSACHUSETTS			
APPLICANT: KEUKA TRUST 311 GREAT ROAD LITTLETON, MASSACHUSETTS			
PO BOX 957 ACTON, MASSACHUSETTS 01720 www.MarkleyAndRubin.com Markley & Rubin CIVIL ENGINEERING			
NOI SHEET 1 OF 2			

DATE: 5/11/21
 COPYRIGHT 2021, MARKEY & RUBIN, INC.

108# 5004

EROSION CONTROL AND SEDIMENTATION NOTES:

1. CONSTRUCT "TEMPORARY CONSTRUCTION ENTRANCE" AS SHOWN ON DETAIL PLAN PRIOR TO THE BEGINNING OF CONSTRUCTION ACTIVITIES. ALL CONSTRUCTION VEHICLES SHALL EXIT THE SITE OVER THIS "TEMPORARY CONSTRUCTION ENTRANCE". THE CONTRACTOR SHALL USE THIS AREA TO REMOVE SOIL FROM THE TIRES OF CONSTRUCTION VEHICLES. "TEMPORARY CONSTRUCTION ENTRANCE" SHALL CONSIST OF SIX TO TWELVE INCHES OF TWO TO THREE INCH STONE.
2. THE SURFACE OF ALL DISTURBED AREAS SHALL BE STABILIZED DURING AND AFTER CONSTRUCTION. TEMPORARY MEASURES SHALL BE TAKEN DURING CONSTRUCTION TO PREVENT EROSION AND SILTATION. TEMPORARY EROSION CONTROL MEASURES SHALL CONFORM WITH THE "MASSACHUSETTS EROSION AND SEDIMENT CONTROL GUIDELINES URBAN AND SUBURBAN AREAS" DATED MARCH 1997 AND SHALL BE APPROVED BY THE ENGINEER. ALL DISTURBED SLOPES WILL BE STABILIZED WITH A 4 TO 6 INCHES OF TOP-SOIL AND A PERMANENT VEGETATIVE COVER. SOME OR ALL OF THE FOLLOWING MEASURES WILL BE UTILIZED ON THIS PROJECT.
 - A. TEMPORARY SEEDING
 - B. TEMPORARY MULCHING (STRAW)
 - C. PERMANENT SEEDING
 - D. PLACEMENT OF SOIL
 - E. HYDROSEEDING
 - F. PLACEMENT OF HAY (WINTER MONTHS)
 - G. PLACEMENT OF JUTE NETTING
3. DUST CONTROL: IF DUST IS GENERATED DURING CONSTRUCTION, ACTIVITIES THEN THE USE OF WATER TRUCKS OR WATER SPRINKLING WILL BE IMPLEMENTED.
4. DEBRIS AND LITTER REMOVAL: DEBRIS AND LITTER SHALL BE KEPT TO A MINIMUM AT ALL TIMES.
5. THE CONTRACTOR IS RESPONSIBLE FOR CLEANING ANY SAND, DIRT, OR DEBRIS WHICH ERODES FROM ROAD CONSTRUCTION THAT MAY REDUCE THE EFFICIENCY OF THE PROTECTIVE MEASURES (SILT BARRIERS, SWALES, PONDS, CHECK DAMS) AND TO PREVENT TRANSPORTING OF SILT OR DEBRIS ONTO PRIVATE PROPERTY OR AREAS BEYOND THE LIMIT OF WORK BOUNDARIES.
6. IF A DRAINAGE OR RUN-OFF PROBLEM OCCURS DURING CONSTRUCTION, THE APPLICANT SHALL TAKE IMMEDIATE CORRECTIVE MEASURES.
7. ANY SILT OR CONSTRUCTION DEBRIS SHALL BE REMOVED FROM THE ACCESS ROAD (GREAT ROAD) AND REMOVED FROM EXISTING DRAINAGE SYSTEM INCLUDING CATCH BASIN SUMPS, PIPELINES, MANHOLES, AND DITCHES IMMEDIATELY UPON DISCOVERY, OR WITHIN 24-HOURS OF BEING NOTED BY THE TOWN. THE STREET SHALL BE SWEEPED AS APPROPRIATE FOR DUST CONTROL.
8. ALL STUMPS SHALL BE EITHER GROUND ON SITE WITH A STUMP GRINDER OR REMOVED FROM SITE FOR PROPER DISPOSAL. NO STUMPS SHALL BE BURIED ON SITE.
9. ALL STOCKPILES SHALL HAVE EROSION CONTROL MEASURES AROUND THE PERIMETER AT ALL TIMES. STOCKPILES SHALL BE LOCATED ONLY WITHIN THE LIMIT OF WORK BOUNDARIES.
10. AT ALL TIMES DURING AND AFTER CONSTRUCTION, COMPACTION OF SOILS IN DESIGNATED RECHARGE AREAS MUST BE MINIMIZED.
11. AT THE COMPLETION OF THE PROJECT ALL DISTURBED AREAS ARE TO BE PERMANENTLY LOAMED AND SEEDED OR PERMANENTLY STABILIZED WITH OTHER SUITABLE GROUND COVER APPROVED BY THE ENGINEER.
12. AFTER THE VEGETATION IS ESTABLISHED AND THE GRADED SLOPES ARE STABILIZED, THE CONTRACTOR WILL REMOVE ALL THE TEMPORARY EROSION CONTROL MEASURES.

CONSTRUCTION SEQUENCE:

- DURING CONSTRUCTION, CONTRACTOR SHALL MAINTAIN EROSION CONTROL BARRIERS. CONTRACTOR SHALL KEEP SPARE EROSION CONTROL SUPPLIES ON SITE CONSISTING OF HAYBALES, STRAW WATTLES AND SILT FENCE TO MAINTAIN AREAS AS NECESSARY. ALL DISTURBED AREAS SHALL BE TREATED WITH HYDROSEED, BONDED FIBER MATRIX, WOOD CHIPS, OR JUTE NET AS SOON AS POSSIBLE FOLLOWING GRADING. EROSION CONTROL MEASURES SHALL NOT BE REMOVED UNTIL SUBSTANTIAL VEGETATION HAS BEEN ESTABLISHED AND THE ENGINEER HAS INSPECTED THE SITE.
1. STAKE OUT LIMIT OF CLEARING, AND INSTALL EROSION CONTROL AS SHOWN ON THE PLANS.
 2. REMOVE TREES, CLEAR AND STUMP SITE. STOCKPILE STUMPS AS SHOWN IN THE STOCKPILE AREAS. PROTECT STOCKPILES FROM EROSION AS SHOWN.
 3. INSTALL CONSTRUCTION ENTRANCE.
 4. REMOVE STUMPS FROM SITE OR GRIND STUMPS ON SITE WITH STUMP GRINDER.
 5. REMOVE AND STOCKPILE TOPSOILS FROM AREAS TO BE DISTURBED - NAMELY HOUSE, SEPTIC SYSTEM AND DRIVEWAY.
 6. ROUGH GRADE DRIVEWAY AND HOUSE AREA.
 7. COMMENCE HOUSE CONSTRUCTION
 8. INSTALL SEPTIC SYSTEM AND FINAL GRADING AROUND SEPTIC SYSTEM.
 9. COMPLETE ROAD CONSTRUCTION WITH FINAL GRADES.
 10. COMPLETE HOUSE CONSTRUCTION AND GRADING AROUND HOUSE.
 11. LOAM AND SEED ALL DISTURBED AREAS.

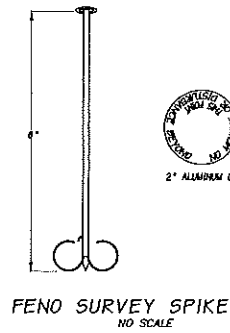

FENOL SURVEY SPIKE & CAP
NO SCALE

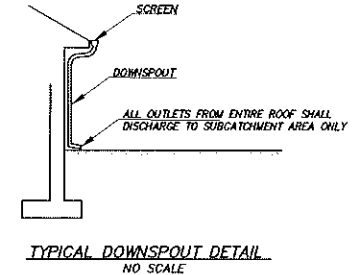

TYPICAL DOWNSPOUT DETAIL
NO SCALE

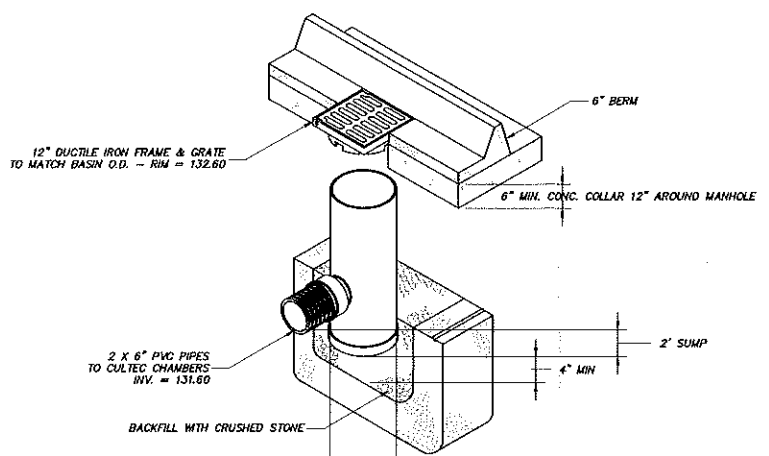

NYLOPLAST 12" CATCH BASIN
FOR H-20 LOADING

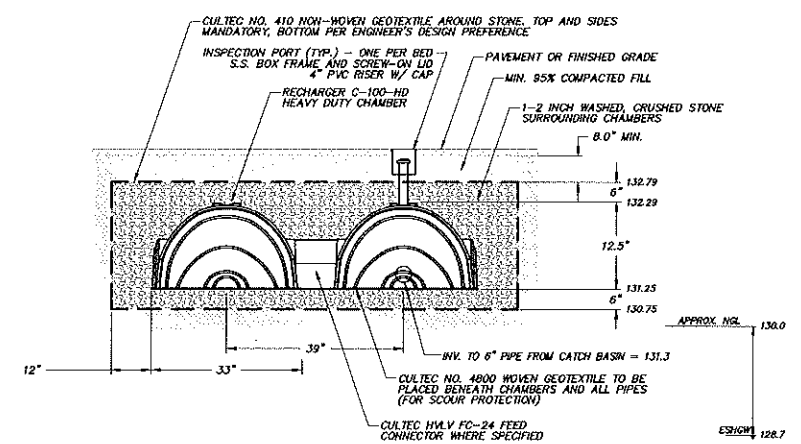

CULTEC RECHARGER C-100-HD CHAMBER SYSTEM
STORMWATER INFILTRATION SYSTEM
NO SCALE

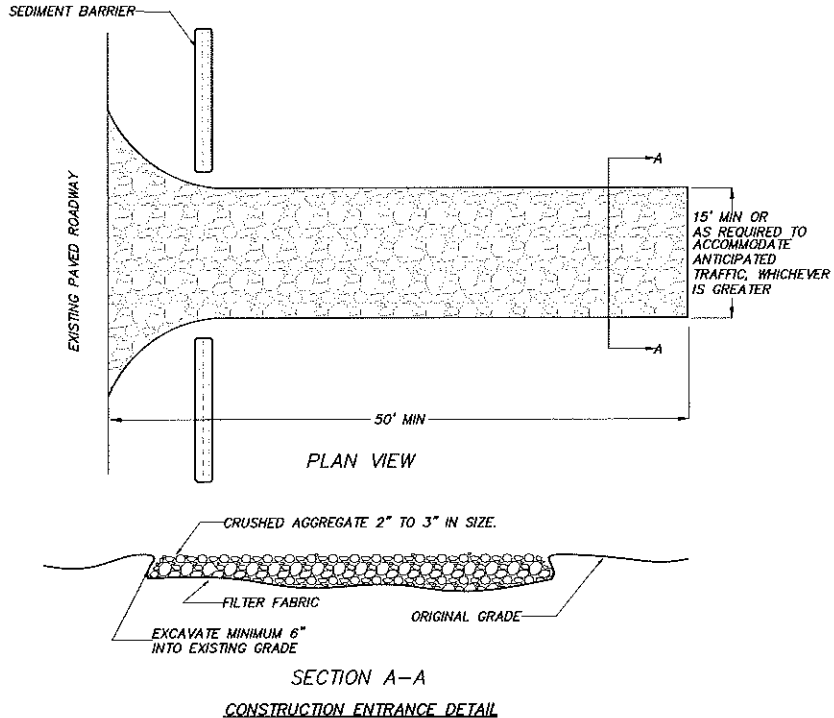

SECTION A-A
CONSTRUCTION ENTRANCE DETAIL

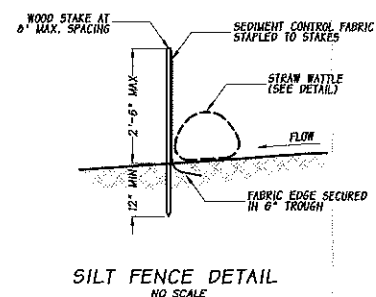

SILT FENCE DETAIL
NO SCALE

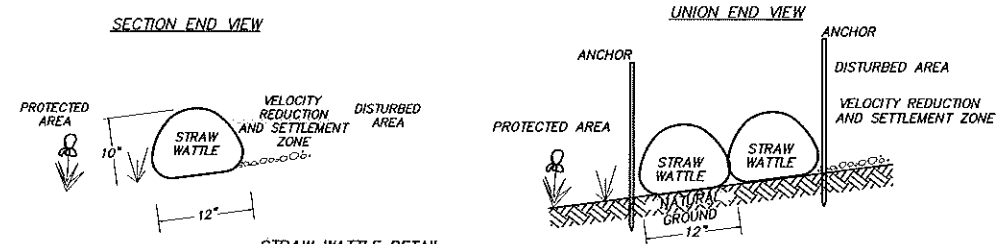

STRAW WATTLE DETAIL
NO SCALE

1. WATTLES SHALL BE CONSTRUCTED OF BIODEGRADABLE TUBULAR PLASTIC OR SIMILAR MATERIAL, AND SHALL BE FILLED WITH STRAW OR MULCH.
2. INSTALL WATTLES IN LOCATIONS SHOWN ON THE PLAN.
3. INSTALL THE WATTLES SNUGLY INTO A 3-5" DEEP TRENCH AND OVERLAP AS SHOWN IN THE DETAIL.
4. INSTALL ANCHOR STAKES ON DOWNHILL SIDE OF THE WATTLES, AND AT 5' SPACING ALONG THE LENGTH OF THE WATTLE.
5. AT A MINIMUM, ANCHOR STAKES SHALL BE 3/4" SQUARE BY 24" LONG. EXISTING VEGETATION GREATER THAN 2" DIAMETER MAY BE USED AS ANCHORS.
6. INSPECT WATTLES AFTER RAINFALL EVENTS TO ENSURE THEY ARE IN CONTACT WITH THE SOIL AND THOROUGHLY ENTRENCHED, AND REPAIR AS NEEDED.
7. INSPECT DOWNGRADIENT SLOPE AFTER SIGNIFICANT RAINFALL EVENTS TO ENSURE SCOUR IS NOT OCCURRING UNDER THE WATTLES, AND REPAIR AS NECESSARY.

#	DATE	REVISION COMMENT

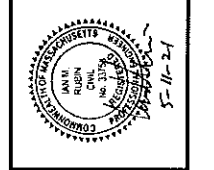

EROSION & SEDIMENT CONTROL & DETAILS PLAN
KEUKA ROAD
CONCORD, MASSACHUSETTS

KEUKA TRUST
311 GREAT ROAD
LITTLETON, MASSACHUSETTS

APPLICANT:
380 MASSACHUSETTS AVE SUITE 202
ACTON, MASSACHUSETTS 01720
P(978) 264-4600 F(978) 263-0447
www.MarkleyAndRubin.com

Markley & Rubin
CIVIL ENGINEERING

DATE: 5/11/21
COPYRIGHT 2021, MARKLEY & RUBIN, INC.

108# 5004